

Table Saw

I. Competencies

Given a properly adjusted table saw, instruction and demonstration of use, each student will be able to:

- A. Identify the major parts of the table saw.
- B. Pass a written test on safety and operating procedures of the table saw with a minimum of 100% accuracy.
- C. Demonstrate, on a performance test, acceptable ability to safely crosscut, rip, bevel, miter and dado with the table saw.

II. Instructional Material and Procedures

A. Identification of Basic Table Saw Parts

- | | |
|-------------------------|--|
| 1. Blade guard | 8. Fence lock |
| 2. Table insert | 9. Fence carriage |
| 3. Table | 10. Off-On switch |
| 4. Miter head | 11. Blade lowering and raising handwheel |
| 5. Blade tilt handwheel | 12. Front rail |
| 6. Table slot | |
| 7. Fence | |

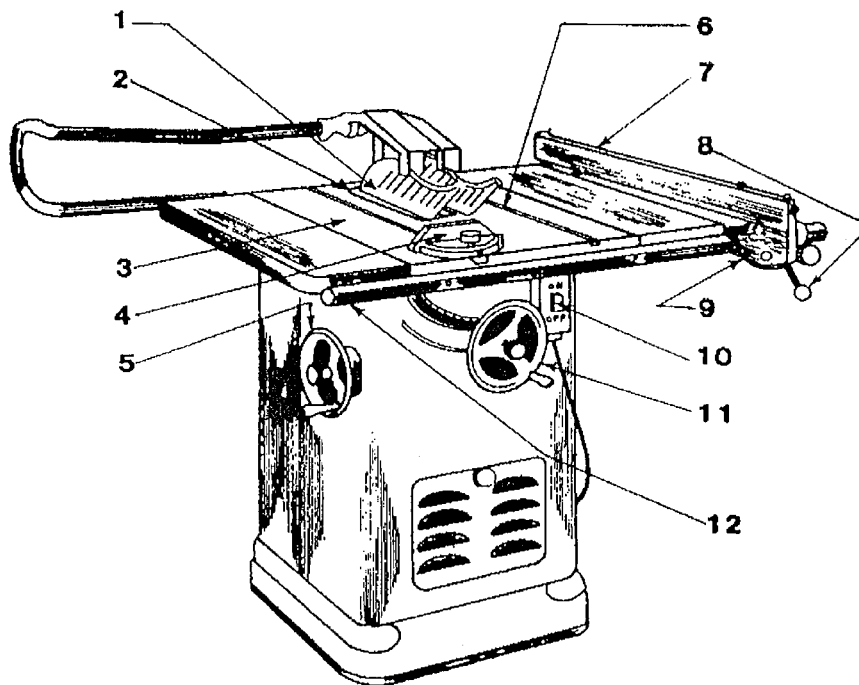

B. Table Saw Safety

1. Remove or fasten loose articles of clothing such as long sleeves, coats, neck ties, etc.
2. Gloves should not be worn when operating a table saw.
3. Remove rings, bracelets and other jewelry which have the potential for getting caught on the table saw or material.
4. Wear industrial quality eye and ear protection while using the table saw.
5. Keep the saw table and floor free of tools, wood stock scraps, sawdust, oil and grease.
6. Check the saw blade periodically for missing teeth and cracks.
7. When saw blades are changed, make certain the blade arbor nut is tightened securely.
8. Stand to one side of the saw blade when cutting; do not allow others to stand in direct line with the saw blade while the saw is operating.
9. Make certain the saw guard, splitter (if available with the guard), anti-kickback device and push stick are used for all possible sawing operations.
10. Never reach over the saw blade to remove or hold down a piece of stock.
11. Wait until the blade comes to a complete stop before leaving the table saw work area.
12. Devote your undivided attention to the work being performed on the table saw. Do not talk to others or be engaged in "horseplay" while using the table saw.
13. Avoid awkward work positions which may result in slips and contact with the saw blade.
14. Support long and wide stock when sawing. Always use a helper to off-bear when cutting large stock.
15. Disconnect the table saw electrical service at the circuit breaker or fuse box before changing blades or before making any service adjustments to the machine.
16. Never raise the saw blade more than $\frac{1}{4}$ inch above the material being cut. Lower the blade below the table top before leaving the saw work area.
17. Round stock should not be ripped on a table saw.
18. When making bevel cuts, always keep hands and stock to the right of the saw blade.
19. Never remove small scraps from the saw until the blade has come to a complete stop. Use a push stick to remove all scrap from the saw blade.

C. Table Saw Operating Procedures

1. Ripping

- a. Always use the saw guard, splitter (if equipped), and anti-kickback device. If a splitter is available, make sure it is aligned with the blade before being used.
- b. Before making cuts, align and lock the rip fence in position. When possible position the rip fence to the right of the saw blade.
- c. If the work piece does not have a straight edge, fasten an auxiliary board to the top of the work piece to provide a straight edge for the first cut.
- d. Set the rip fence for desired width of cut using the scale on the front rail or, for more accurate cuts, measure the distance between the blade teeth and the fence.
- e. Use the left hand to hold the board against the fence and table. Use the right hand to push the material through the saw. When the stock is less than 6 inches in width, use a pushstick to push the trailing end through the saw. Never allow the hands to come closer than 12 inches to the saw blade. Position the right hand so it is NOT in direct line with the saw blade. Remove the hand holding the stock down as it approaches the saw blade guard. For narrow ripping cuts, where a push stick cannot be used, use a push block or an auxiliary fence. (Use reverse procedure for left handed persons).
- f. Always push the work piece completely past the blade at the end of a cut to reduce the possibility of kickback.
- g. When ripping long boards use a support at the front of the table or an off-bearer to support the cut stock as it comes through the saw. The off-bearer never pulls the stock, he/she only supports and move with the stock as it comes through the saw.
- h. For materials shorter than 12 inches or narrower than 6 inches always use a push stick or push block to push material between the fence and the saw blade.
- i. Never attempt to set the rip fence when the carriage extends beyond the end of the front rail.
- j. Make sure the correct blade is used for ripping cuts.
- k. If the lumber is warped, turn the curved side down when ripping.

2. Crosscutting

- a. Make sure the saw guard and splitter are in place when crosscutting.
- b. Always use the miter gauge when crosscutting. Be sure the miter head is set at the proper angle for the desired cut and securely clamped.
- c. Most workers prefer to use the left table slot for the miter gauge when crosscutting.
- d. Hold the stock against the miter head with the left hand and use the right hand to advance the miter gauge and material through the cut.

- e. Use the right table slot for making bevel or chamfer cuts. The right table slot is used for this operation so the blade will tilt away from the operator's hands and the miter gauge.
- f. Always hold the material firmly against the miter head to prevent vibration and binding when the cut is made.
- g. To improve the effectiveness of the miter head, some workers mount an auxiliary extension to the miter head. This extension should not extend beyond the left edge of the saw table.
- h. Provide support for any material which extends beyond the edge(s) of the saw table.
- i. The miter head should be used when making cuts from 90 degrees to 45 degrees. The miter head should be adjusted relative to the slot in the saw table. If needed, change the position of the pointer and stops on the miter head gauge to accurately read the degrees for miter cuts.

3. Bevel and Miter Cutting

- a. The saw guard, splitter (if available) and anti-kickback device should be in place when making bevel and miter cuts
- b. When beveling or making compound miter cuts always use the fence or the miter head on the opposite side from which the blade is tilted. This will maximize the distance the hands will be from the blade and help avoid binding between the saw blade and the table top.
- c. Bevel cutting is performed the same as described for ripping; miter cutting is performed the same as described for crosscutting.
- d. Miter head hold down clamps may be used to hold stock in place for accurate miter cuts.

4. Dadoing

- a. Make sure the electrical service is turned off in the circuit breaker before installing dado blades
- b. Use a table insert which fits the dado cut being made. Several wood table inserts, with varying slot widths, should be made and kept on hand for use with the dado blades.
- c. Hold down blocks should be used for holding down stock while making groove cuts with the dado head.
- d. Use of an auxiliary board mounted on the rip fence is recommended of cutting groove joints with the dado head.
- e. The miter head is used to hold stock for making dado cuts.

- f. Replace the saw blade, guard, splitter, anti-kickback device, and table insert immediately after dado cuts are completed.

III. Written Test

Table Saw Safety and Operation Test

Name _____ Date _____ Class _____

Multiple Choice – Place the letter of the most correct answer on the answer sheet.

1. What should be done with articles of clothing such as ties, coats and long sleeves when operating the table saw?
 - a. Keep them away from the saw blade
 - b. Remove or fasten them out of the way
 - c. Do not get close to the saw
 - d. Have a student hold them out of the way

2. Which of the following items should NOT be worn when operating the table saw?
 - a. Rings
 - b. Gloves
 - c. Bracelets
 - d. All of these

3. Personal protective equipment which should be worn when operating the table saw is/are _____.
 - a. gloves
 - b. ear protectors
 - c. safety glasses
 - d. both b and c

4. When setting the table saw up for a job, the saw blade should be checked for _____.
 - a. stripped threads
 - b. loss of temper
 - c. cracks and missing teeth
 - d. distorted arbor

5. The arbor nut on a table saw is tightened only when _____.
 - a. it becomes loose
 - b. the electrical service is disconnected at the circuit breaker
 - c. the class is over by the teacher
 - d. permission is granted

6. To prevent slipping of falling when using the table saw _____.
 - a. turn the saw off before removing material
 - b. stay within the safety zone
 - c. do not over-reach when feeding material through the saw
 - d. wear tennis shoes

7. When sawing with the table saw, which of the following would not be a safe practice?
- Use the blade guard
 - Secure a helper to support the material being sawed
 - Push the material through the saw with the right hand and a push stick
 - Stand in line with the saw blade
8. After a cut has been completed, what should the operator do before leaving the table saw?
- Turn the electrical service off at the circuit breaker or fuse box
 - Clear the work zone of all students
 - Make sure the saw blade has stopped turning
 - Lock the blade
9. When making a rip or crosscut, the saw blade should extend no more than _____ inches above the stock being cut.
- $\frac{1}{4}$
 - $\frac{1}{8}$
 - $\frac{3}{8}$
 - $\frac{1}{2}$
10. When bevel or chamfer cuts are made, the hands of the operator should be _____.
- Slightly to the right of the table edge
 - In front of the saw blade
 - Opposite side from which the blade is tilted
 - One hand on the right and one hand on the left of the blade

11. Which type of stock should never be ripped on the table saw?
- Square stock
 - Thick stock
 - Round stock
 - Flat stock
12. Which of the following operations require the use of a push stick on the table saw?
- Ripping narrow materials
 - Crosscutting
 - Mitering
 - Dadoing
13. Which table saw accessory gives width settings for the rip fence?
- Front rail
 - Rear table rail
 - Table ruler
 - Miter head
14. A push stick must be used if material is less than _____ inches in width.
- 4
 - 6
 - 8
 - 10
15. The purpose of the off-bearer, in table saw operation, is to _____.
- pull the stock through the saw
 - support the stock as it is pushed through the saw
 - support and pull the stock through the saw
 - remove scraps, support and help pull stock through the saw
16. When ripping warped lumber the bow should be turned _____.
- down
 - up
 - horizontally
 - perpendicular to the blade
17. The maximum distance the rip fence can safely be set from the saw blade is _____.
- 36 inches
 - the distance measured when the carriage is flush with the end of the front rail
 - 48"
 - 12 inches on a 12" table saw

18. The accessory used when crosscutting on the table saw is the _____.
- a. front rail
 - b. miter head
 - c. fence
 - d. table slot
19. When crosscutting, most table saw operators prefer to work on the _____ side of the saw blade.
- a. right
 - b. left
 - c. both of these
 - d. neither of these
20. The miter head gauge is calibrated in _____.
- a. inches
 - b. feet
 - c. degrees
 - d. inches/centimeters
21. The miter head and right hand table slot are recommended for use when _____.
- a. right angle rip cuts are to be made
 - b. compound bevel crosscuts are to be made
 - c. ripping short pieces
 - d. ripping multiple cuts of the same size
22. When stock is held loosely against the miter head one may experience _____.
- a. poor cuts
 - b. binding of the blade
 - c. material vibration
 - d. all of these
23. When long materials are crosscut on the table saw the operator needs _____.
- a. auxiliary support
 - b. a pushstick
 - c. a properly adjusted fence
 - d. all of the above

Table Saw Parts Identification Test

Name _____

Match the number of each table saw part with the correct part name.

___ A. Switch

___ B. Fence carriage

___ C. Table

___ D. Fence

___ E. Blade tilt handwheel

___ F. Fence lock

___ G. Front Rail

___ H. Blade guard

___ I. Blade lowering and raising handwheel

___ J. Table slot

___ K. Miter head

___ L. Table insert

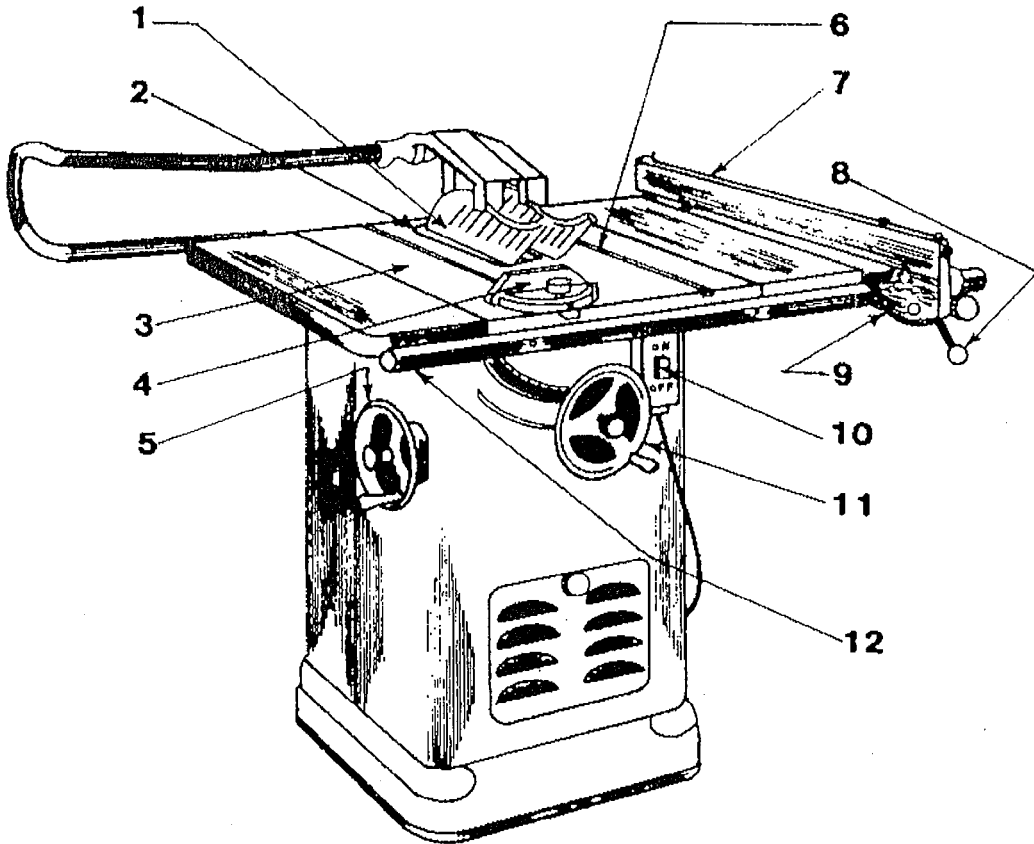

BASIC TABLE SAW PARTS

