

## NYS Mathematics Glossary\* – Integrated Algebra

(\*This glossary has been amended from the full SED Commencement Level Glossary of Mathematical Terms (available at <http://www.emsc.nysed.gov/ciai/mst/math/glossary/home.html>) to list only terms at the Intermediate Algebra level.)

This Glossary, intended for teacher use only, provides an understanding of the mathematical terms used in the Regents-approved course entitled Integrated Algebra (as reflected in the NYS Mathematics Core Curriculum).

### A

**absolute value** The distance from 0 to a number  $n$  on a number line. The absolute value of a number  $n$  is indicated by  $|n|$ .

**Example:**  $|-3| = 3$ ,  $|+3| = 3$ , and  $|0| = 0$ .

**absolute value function** A function containing the absolute function of a variable.

**Example:**  $f(x) = |x| = \begin{cases} x, & x \geq 0 \\ -x, & x < 0 \end{cases}$

**accuracy** How close a numerical measure is to its actual value.

**acute angle** An angle whose measure is greater than  $0^\circ$  and less than  $90^\circ$ .

**adjacent angles** Two coplanar angles that share a common vertex and a common side but have no common interior points.

**Example:** In the figure below,  $\angle AOB$  and  $\angle BOC$  are a pair of adjacent angles, but  $\angle AOC$  and  $\angle BOD$  are not adjacent.

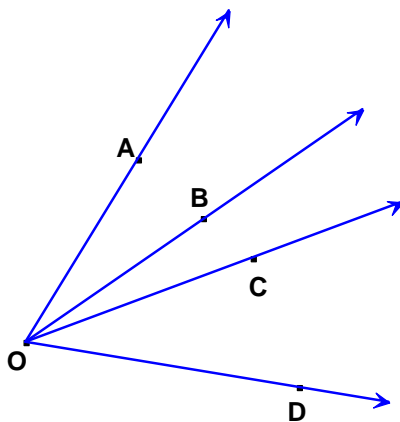

**adjacent side of an acute angle in a right triangle** The leg of the right triangle that is a side of the acute angle.

**Example:** In right triangle  $ABC$  below,  $\overline{AC}$  is adjacent to angle  $A$  and  $\overline{BC}$  is adjacent to angle  $B$ .

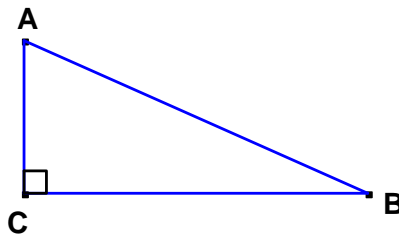

**algebra** The branch of mathematics that uses letters and/or symbols, to represent numbers and express mathematical relationships.

**algebraic equation** A mathematical statement that is written using one or more variables and constants which contains an equal sign.

**Examples:**  $3y + 5 = 1$  ;  $2^x = 1/8$

**algebraic expression** A mathematical phrase that is written using one or more variables and constants, but which does not contain a relation symbol ( $<$ ,  $>$ ,  $\leq$ ,  $\geq$ ,  $=$ ,  $\neq$ )

**Examples:**  $3y + 5$  ;  $2^x$

**algebraic fraction** A fraction that contains an algebraic expression in its numerator and/or denominator.

Example:  $\frac{2x+4}{x+2}$ .

**algebraic representation** The use of an equation or algebraic expression to model a mathematical relationship.

**algorithm** a defined series of steps for carrying out a computation or process.

**analyze** to examine methodically by separating into parts and studying their relationships.

**angle** A geometric figure formed by two rays that have a common endpoint.

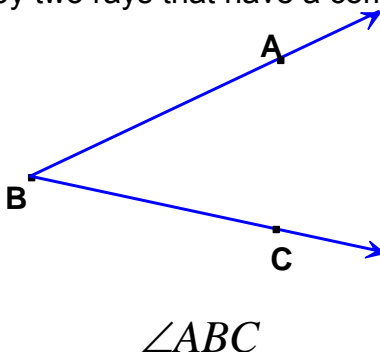

**angle of depression** The angle formed by the horizontal and the line of sight when looking downward.

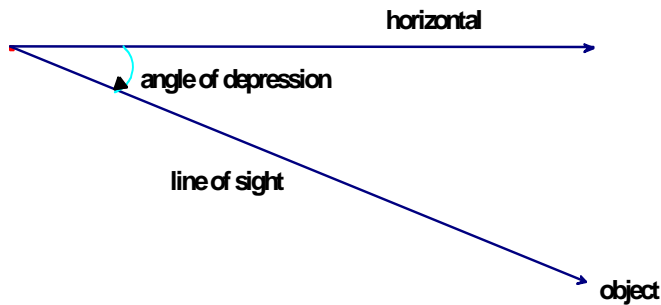

**angle of elevation** The angle formed by the horizontal and the line of sight when looking upward.

**Example:**

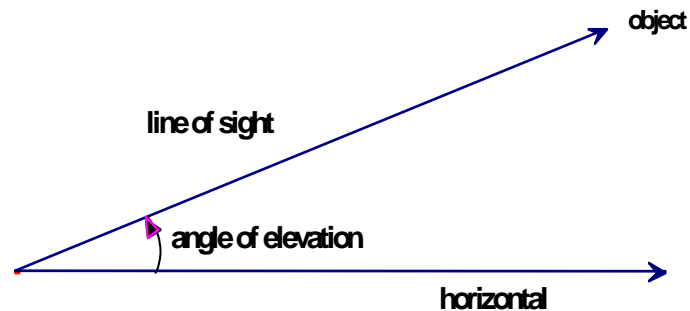

**appropriateness** Reasonableness of an answer or method.

**approximate value** A value for some quantity, accurate to a specified degree.

**Example:** A board that measures 4 feet 2 inches has an approximate length to the nearest foot of 4 feet.

**argument** The communication, in verbal or written form, of the reasoning process that leads to a valid conclusion.

**array** A set of objects or numbers arranged in an order, usually in rows and columns.

**associative property** A property of real numbers that states that the sum or product of a set of numbers or variables has the same value, regardless of how the numbers or variables are grouped.

**Examples:** Addition:  $2x + (3.5y + 1.3z) = (2x + 3.5y) + 1.3z$   
 Multiplication:  $-6a \times (18b \times 7c) = (-6a \times 18b) \times 7c$

**axis** A horizontal or vertical line used in the Cartesian coordinate system used to locate a point.

## B

**base** A number or an expression that is raised to a power.

**Example:**  $x+2$  is the base in the expression  $(x+2)^3$ , and 5 is the base in the expression  $5^y$ .

**binomial** An algebraic expression consisting of two terms.

**Examples:**  $5a + 6$   
 $x^2 + 3y$   
 $9m - 13p$

**bivariate data** Data involving two variables.

**box-and-whisker plot** A visual display of a set of data showing the five number summary: minimum, first quartile, median, third quartile, and maximum. This plot shows the range of scores within each quarter of the data. It is very useful for examining the variation in a set of data and comparing the variation of more than one set of data.

**Example:**

**Annual food expenditures per household in the U.S. in 2005**

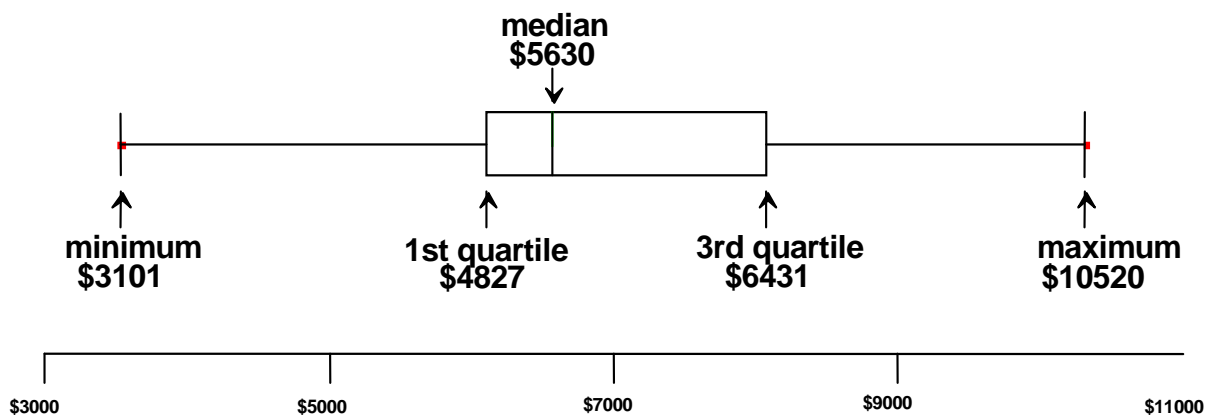

# C

**center-radius equation of a circle** The form of the equation of a circle with center  $(h, k)$  and radius  $r$  given by the formula  $(x-h)^2 + (y-k)^2 = r^2$ .

**Example:** If the coordinates of the center of the circle are  $(3, -4)$  and the length of the radius is 5, then the equation of the circle is  $(x-3)^2 + (y+4)^2 = 5^2$ .

**circle** The set of all points (or locus of points) in a plane that are a fixed distance, (called the radius) from a fixed point, (called the center).

**closure** A set “S” and a binary operation “\*” are said to exhibit closure if applying the binary operation to any two elements in “S” produces a value that is a member of “S”.

**coefficient** The numerical factor of a term in a polynomial.

**Example:** 14 is the coefficient in the term  $14x^3y$ .

**common base(s)** Exponential expressions or equations that have the same or equivalent bases.

**Example:**

- a) 2 is the common base in  $2^3$  and  $2^4$ .
- b) In the equation  $3^x = 3^2$ , the common base is 3.

**common factor** A number, polynomial, or quantity that divides two or more numbers or algebraic expressions evenly.

**Example:**

- 1, 3, 5, 15, are common factors of 15 and 30
- $2x$  is a common factor of  $4xy$  and  $6x^2$
- $x-2$  is a common factor of  $x^2 - x - 2$  and  $x^2 - 6x + 8$

**commutative property** A property of real numbers that states that the sum or product of two terms is unaffected by the order in which the terms are added or multiplied; i.e., the sum or product remains the same.

**Examples:** Addition:  $-2x + 3.5y = 3.5y + -2x$   
 Multiplication:  $xy^2 = y^2x$

**compare** To state the similarities or differences between two or more numbers, objects, or figures by considering attributes such as size, shape, odd, even.

**complement of a set** The elements of a universe not contained in a given set; the subset that must be added to any given subset to yield the original set. The complement of set A is indicated by  $A'$  or  $A^C$ .

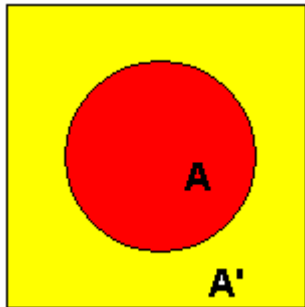

Universe = interior of the square

Set A= the circular region

Complement of A is  $A'$  (or  $A^C$ )

**conclusion** An answer or solution arrived at through logical or mathematical reasoning; the “then” clause in an “if-then” statement; the final statement in a proof which follows logically from previous true statements.

**conditional probability** A probability that is computed based on the assumption that some event has already occurred. The probability of event B given that event A has occurred is written  $P(B|A)$ .

**conjecture** An educated guess; an unproven hypothesis based on observation, experimentation, data collection, etc.

**coordinates** An ordered pair of numbers that identifies a point on a coordinate plane, written as  $(x, y)$ . The number represented by “x” is called the x-coordinate (abscissa). The number represented by “y” is called the y-coordinate (ordinate).

**Example:** In Cartesian coordinates  $(2,3)$  the number 2 is the x-coordinate (abscissa) and 3 is the y-coordinate (ordinate).

**correlation** A statistical measure that quantifies how pairs of variables are related; a linear relationship between two variables.

**cosine** For a given acute angle  $\theta$  in a right triangle, the ratio of the length of the side adjacent to an acute angle to the length of the hypotenuse. The cosine of an angle is written as  $\cos$ . See also circular function.

**Example:** In this right triangle,  $\cos A = \frac{3}{5}$  and  $\cos B = \frac{4}{5}$

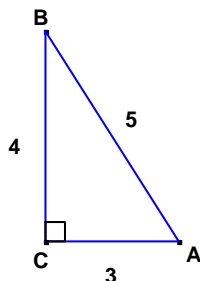

**cubic unit** A unit for measuring volume.

**cumulative frequency table** A table that shows how often each item, number, or range of numbers occurs in a set of data. This table displays the total number of scores that fall into each of several cumulative intervals. The cumulative intervals are created by adding the preceding tallies (of lower scores) to the new tallies for each interval.

**Example:** 5 , 7 , 6 , 8 , 9 , 5 , 13 , 2 , 1 , 6 , 5 , 14 , 10 , 5 , 9

Interval	Frequency	Cumulative Frequency
1-5	6	6
1-10	7	13
1-15	2	15

**cumulative frequency histogram** A histogram where each bar contains all the data up to and including the data in that bar's interval.

**Example:** This histogram shows the number of students in Mrs. Simpson's class that are in each interval. The students were asked how many hours they spent playing video games in one week.

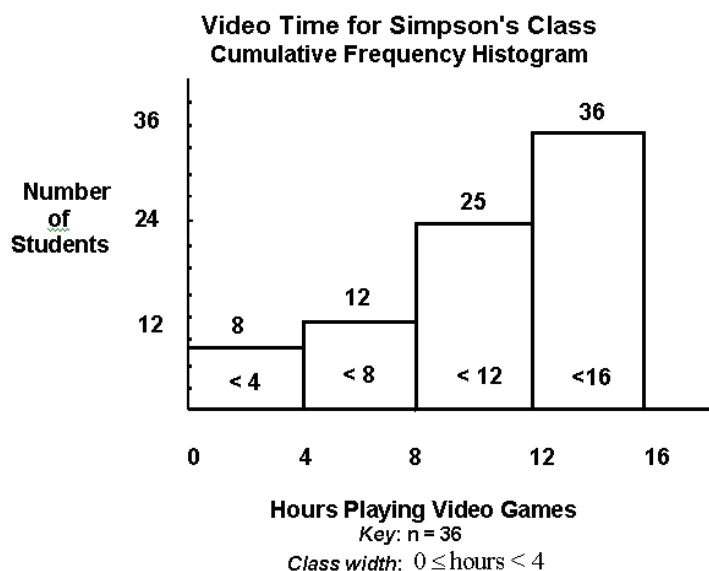

**cylinder** A solid geometric figure bounded by two parallel bases which are congruent circles and a lateral surface which consists of the union of all line segments joining points on each of those circles.

**Example:**

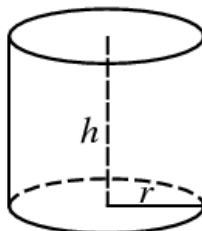

## D

**decagon** A polygon with ten sides.

**degree of a monomial** The sum of the exponents of the variables in the monomial.

**Example:** The degree of the monomial  $4x^3$  is three.

The degree of the monomial  $x^2y^3$  is five.

The degree of  $xy$  is two.

The degree of 7 is zero.

**degree of a polynomial** The highest degree of any monomial term in the polynomial.

**dependent events** Two events in which the outcome of the first event affects the outcome of the second event

**Example:** The probability of choosing a king on the second draw, is dependent on whether or not a king was chosen on the first draw if the card was not replaced.

**dependent variable** A variable whose value is determined by a second variable.

**difference of two perfect squares** A binomial of the form  $a^2 - b^2$  which can be factored into  $(a - b)(a + b)$ .

**distributive property (A)** A property of real numbers that states that the product of a number and the sum or difference of two numbers is the same as the sum or difference of their products.

**Example:** Multiplication over addition:  $2(15 + 4) = 2 \times 15 + 2 \times 4$

Multiplication over subtraction:  $4(12 - 8) = 4 \times 12 - 4 \times 8$

## E

**element** An object contained in a set.

**empirical probability** An estimate of the probability of an event based on the results of repeated trials of the event.

**equation** A mathematical sentence stating that two expressions are equal.

**exponent** A number that tells how many times the base is used as a factor of a term; in an expression of the form  $b^n$ ,  $n$  is called the exponent,  $b$  is the base, and  $b^n$  is a power of  $b$ .

**exponential decay (A)** The decreasing exponentially of a quantity over time represented by  $y = a \cdot b^x$  where  $a > 0$  and  $0 < b < 1$ .

**Example:**  $y = 5(0.1)^x$ . Each time  $x$  is increased by 1,  $y$  decreases to one tenth of its previous value.



**exponential form** An expression or equation containing exponents.

**Examples:**

In exponential form,  $3^2 = 9$  and  $32 = 2^5$ .

**exponential function** A function with a variable in the exponent; an equation in the form  $y = ab^x$ , where  $a \neq 0$  and  $b > 0, b \neq 1$ .

**Example:**  $A = 3(1.02)^t$  is an exponential function

**exponential growth** The increasing exponentially of a quantity over time represented by  $y = a \cdot b^x$  where  $a > 0$  and  $b > 1$ .

**Example:**  $y = 5(2)^x$ . Each time  $x$  is increased by 1,  $y$  increases by a factor of 2

**expression** A mathematical representation containing numbers, variables, and operation symbols; an expression does not include an equality or inequality symbol.

**extrapolate** The process of using a given data set to estimate the value of a function or measurement beyond the values already known.

## F

**factor** (noun) A whole number that is a divisor of another number; an algebraic expression that is a divisor of another algebraic expression.

**Example:** 3 is a factor of 12

**factor** (verb) Find the number of algebraic expressions that give an indicated product.

**Example:** To factor  $x^2 - x - 6$ , write  $(x - 3)(x + 2)$ .

**factorial** The product of a given integer and all smaller positive integers.  $n$  factorial is written as  $n!$ . Note:  $0! = 1$  and  $1! = 1$ .

**Example:**

$$6! = 6 \cdot 5 \cdot 4 \cdot 3 \cdot 2 \cdot 1 = 720$$

$$n! = n \cdot (n - 1) \cdot (n - 2) \cdot \dots \cdot 3 \cdot 2 \cdot 1$$

**five number summary** For a data set, these include the minimum, the first quartile, the median, the third quartile, and the maximum.

**frequency table** A table that shows how often each item, number, or range of numbers occurs in a set of data.

**Example:** The data {5, 7, 6, 8, 9, 5, 13, 2, 1, 6, 5, 14, 10, 5, 9} can be displayed as a frequency distribution.

Interval	Frequency
1-5	6
6-10	7
11-15	2

**function** A rule that assigns to each number  $x$  in the function's domain a unique number  $f(x)$ .

## G

**geometry** Branch of mathematics that deals with the properties, measurement, and relationships of points, lines, angles, surfaces, and solids.

**graphical representation** A graph or graphs used to model a mathematical relationship.

**Example:** The figure below is a graphical representation of the locus of all points 4 units from  $A(10,7)$  and 3 units from  $x = 8$ .

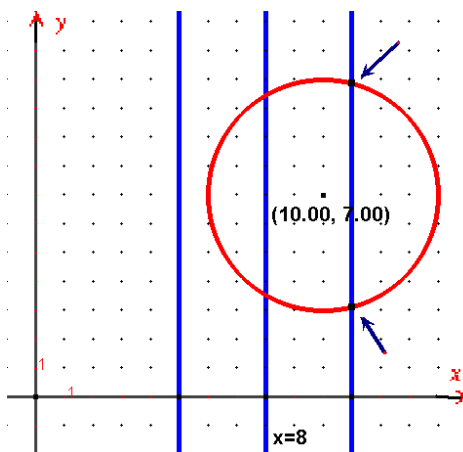

**graphical solution of a system of equations** The set of points in the plane whose coordinates are solutions to a system of equations.

**greatest common factor (GCF)** The greatest number or expression that is a factor of two or more numbers or expressions.

**Example:** 12 is the GCF of 24 and 36.  
 $5xy$  is the GCF of  $25x^2y$  and  $10xy^2$

# H

**hexagon** A polygon with six sides.

**Examples:**

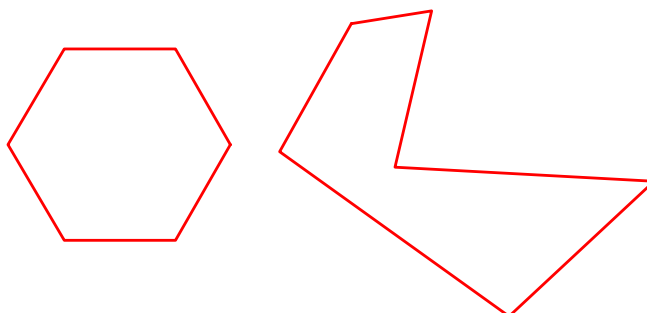

**histogram** A frequency distribution for continuous quantitative data. The horizontal axis is a number line that displays the data in equal intervals. The frequency of each bar is shown on the vertical axis.

**Example:** This histogram shows the number of students in Simpson's class that are in each interval. The students were asked how many hours they spent playing video games in one week.

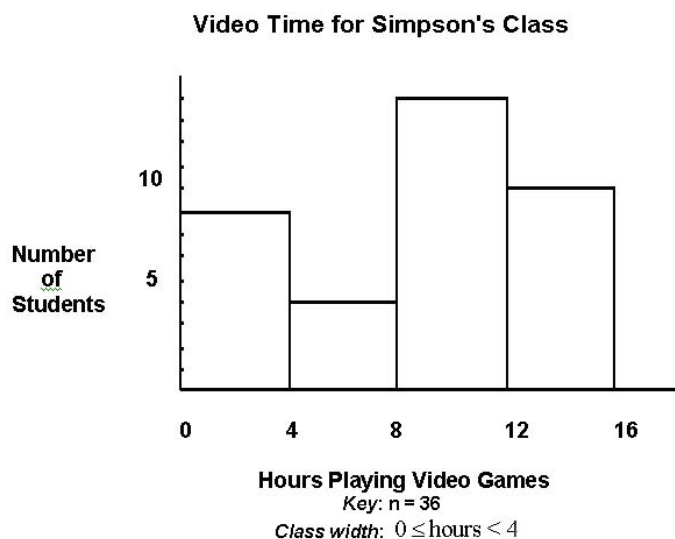

**hypotenuse** The side of a right triangle opposite the right angle; the longest side of a right triangle.

**Example:**



# I

**identities** Equations that are true for all values of the variables they contain.

**Example:**  $x + 2 = 2 + x$

**identity elements** For a binary operation  $*$  and a set  $S$ ,  $I$  is the identity element if  $a * I = a$  and  $I * a = a$  for every element  $a$  that is in  $S$ .

**Examples:** (1) For addition (+) and the set of Integers, the number 0 is the identity element, because for every integer  $a$ :  $0 + a = a$  and  $a + 0 = a$ .  
 (2) For multiplication ( $\times$ ) and the set of Real Numbers, the number 1 is the identity element, because for every Real Number  $a$ :  $1 \times a = a$  and  $a \times 1 = a$ .

**image** The resulting point or set of points under a given transformation; in any function  $f$ , the image of  $x$  is the functional value  $f(x)$  corresponding to  $x$ .

**Example:** In the function  $f(x) = x^2 + 3$ , 7 is the image of 2 under  $f$ .

**impossible event/outcome** An event that cannot occur. The probability of an impossible event equals zero.

**Example:** rolling a total of 13 when tossing two six-sided number cubes labeled 1 to 6.

**independent events** Two or more events in which the outcome of one event has no effect on the outcome of any other event.

**independent variable** An element in the domain of a function; the input value of a function.

**inductive reasoning** The process of observing data, recognizing patterns and making generalizations about those patterns.

**inequality** A mathematical statement containing one of the symbols  $<$ ,  $>$ ,  $\leq$ ,  $\geq$ ,  $\neq$  to indicate the relationship between two quantities.

**integers** The set of numbers that is the union of the counting numbers, their opposites, and zero (i.e.,  $\{\dots -4, -3, -2, -1, 0, 1, 2, 3, 4, \dots\}$ ).

**interpolate** The process of using a given data set to estimate the value of a function or measurement between the values already known.

**intersection of sets** The intersection of two or more sets is the set of all elements that are common to all of the given sets.

**Example:** If  $A = \{1, 2, 3, 6\}$  and  $B = \{0, 2, 5, 6, 7\}$ , then the intersection of  $A$  and  $B$ , denoted by  $A \cap B$ , is  $\{2, 6\}$

**inverse operation** An operation that undoes another operation; addition and subtraction are inverse operations; multiplication and division are inverse operations; raising to a power and taking a root are inverse operations.

**Examples:** Subtracting four undoes adding four.

Taking the  $n$ th root of a number undoes finding the  $n$ th power of the number.

**J** There are no J terms.

**K** There are no K terms.

**L**

**leading coefficient** The coefficient of the first term of a polynomial when the polynomial is in standard form.

**Examples:** 5 is the leading coefficient of  $5x^2 - 9x + 7$   
 - 4 is the leading coefficient of  $1 - 4n^2 + 7n$

**legs of a right triangle** The two sides of a right triangle that form the right angle.

**like radical terms** Terms that have the same index and the same radicand.

**Examples:**

$4\sqrt[3]{12}$  and  $-5\sqrt[3]{12}$  are like radical terms

$2\sqrt{5y}$  and  $17\sqrt{5x}$  are not like radical terms

**line of best fit** A line used to approximate and generalize the linear relationship between the independent and dependent variables for a set of data. It may not be equivalent to a least squares regression model.

**Example:**

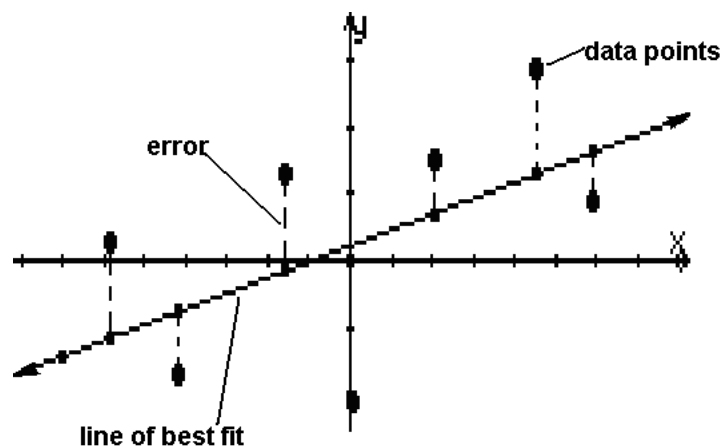

**linear equation** A first degree equation.

**Examples:**  $y = 6x + 8$   
 $12n - 19 = 23 + 7n$

**linear inequality** An inequality of the first degree.

**Example:**  $4s + 3 > -1$   
 $43n + 66 \leq 13 - 17n$   
 $y > 9x - 22$

**linear transformation** A transformation of data set  $X$  is of the form  $X' = a + bX$ , where  $a$  is the additive component and  $b$  is the multiplicative component.

**Example:** Applying the linear transformation  $X' = 10 + 2X$  to the data set  $X = \{3, 5, 6, 8\}$  gives the resulting set  $X' = \{16, 20, 22, 26\}$

**literal equation** An equation that contains more than one variable.

**Example:**  $2a + 3b = c$

**logical argument** A reasoning process based on logic that uses a series of statements leading to a conclusion.

## M

**mean** A measure of central tendency denoted by  $\bar{x}$ , read "x bar", that is calculated by adding the data values and then dividing the sum by the number of values. Also known as the arithmetic mean or arithmetic average.

**measure of central tendency** A summary statistic that indicates the typical value or center of an organized data set. The three most common measures of central tendency are the mean, median, and mode.

**median** A measure of central tendency that is, or indicates, the middle of a data set when the data values are arranged in ascending or descending order. If there is no middle number, the median is the average of the two middle numbers.

**Examples:** The median of the set of numbers:  $\{2, 4, 5, 6, 7, 10, 13\}$  is 6  
 The median of the set of numbers:  $\{6, 7, 9, 10, 11, 17\}$  is 9.5

**mode** A measure of central tendency that is given by the data value(s) that occur(s) most frequently in the data set.

**Examples:**

The mode of the set of numbers  $\{5, 6, 8, 6, 5, 3, 5, 4\}$  is 5.

The modes of the set of numbers  $\{4, 6, 7, 4, 3, 7, 9, 1, 10\}$  are 4 and 7.

The mode of the set of numbers  $\{0, 5, 7, 12, 15, 3\}$  is none or there is no mode.

**monomial** A polynomial with one term; it is a number, a variable, or the product of a number (the coefficient) and one or more variables.

**Examples:**  $6$ ,  $-\frac{3}{4}$ ,  $x^2$ ,  $\frac{1}{8}x^5$ ,  $8a^2b$ ,  $-5.9y$ ,  $m^2n^3p^4$

**multiple representations** Various ways, i.e., graphically, numerically, algebraically, geometrically, and verbally, to present, interpret, communicate, and connect mathematical information and relationships.

**multiplication property of zero** For every number  $a$ ,  $0 \cdot a = 0$  and  $a \cdot 0 = 0$ .

**mutually exclusive events** Two events that cannot occur at the same time.

## N

**nonagon** A polygon with nine sides.

**null set** The set with no elements. The empty set can be written  $\emptyset$  or  $\{ \}$

## O

**octagon** A polygon with 8 sides.

**Examples:**

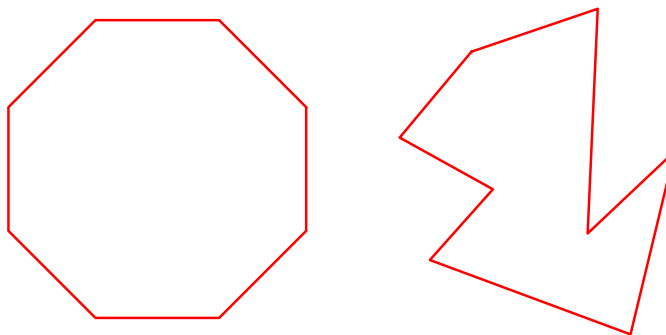

**opposite side in a right triangle** The side across from an angle. In a right triangle the hypotenuse is opposite the right angle and each leg is opposite one of the acute angles.

**Example:** With respect to  $\angle A$ ,  $\overline{BC}$  is the opposite side, and  $\overline{AC}$  is the adjacent side. With respect to side  $\overline{AC}$ ,  $\angle B$  is the opposite angle.

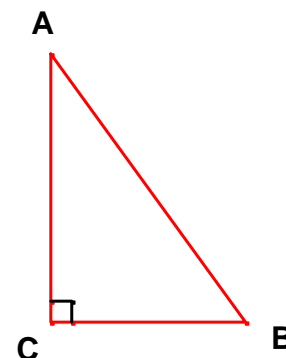

**ordered pair** Two numbers that are used to identify the position of a point in a plane. The two numbers are called coordinates and are represented by  $(x, y)$ .

**ordinate** The vertical coordinate of a two-dimensional rectangular coordinate system; usually denoted by  $y$ .

## P

**parabola** The locus of points equidistant from a given point (called the focus) and a given line (called the directrix). A common form of an equation of a parabola with vertical line symmetry is  $y = ax^2 + bx + c$ , where  $a$ ,  $b$ , and  $c$  are real numbers and  $a \neq 0$ .

**Example:**

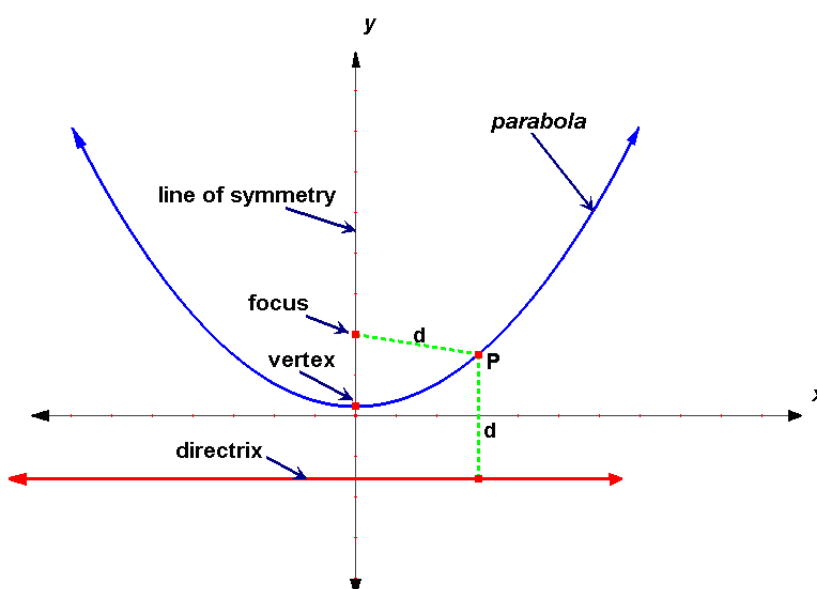

**parallel lines** Two or more coplanar lines that do not intersect. Parallel line segments or rays are line segments or rays that are subsets of parallel lines.

**parallelogram** A quadrilateral in which both pairs of opposite sides are parallel.

**Example:**

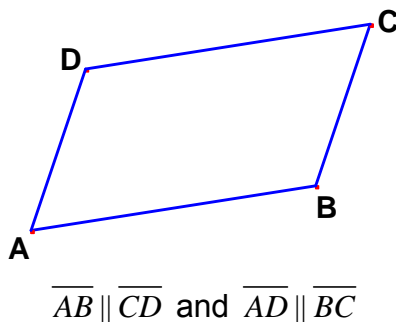



**parameter** A quantity or constant whose value varies with the circumstances of its application.

**Example:** In  $y = ax^2$   $a$  is a parameter

**pentagon** A polygon with 5 sides.

**Examples:**

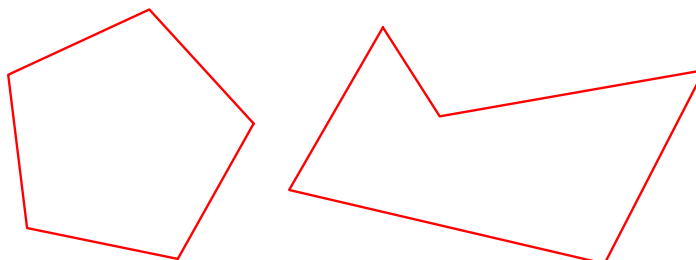

**percent of increase/decrease** The magnitude of increase/decrease expressed as a percent of the original quantity.

**Example:** Mr. Mohamed received a raise of \$5,000 on his annual salary: His previous salary was \$25,000, and his new salary is \$30,000. The raise is a 20% increase of his salary (\$5,000 is 20% of \$25,000).

**perimeter** The sum of the lengths of all the sides of any polygon.

**polygon** A closed plane figure formed by three or more line segments that meet only at their endpoints.

**Examples:**

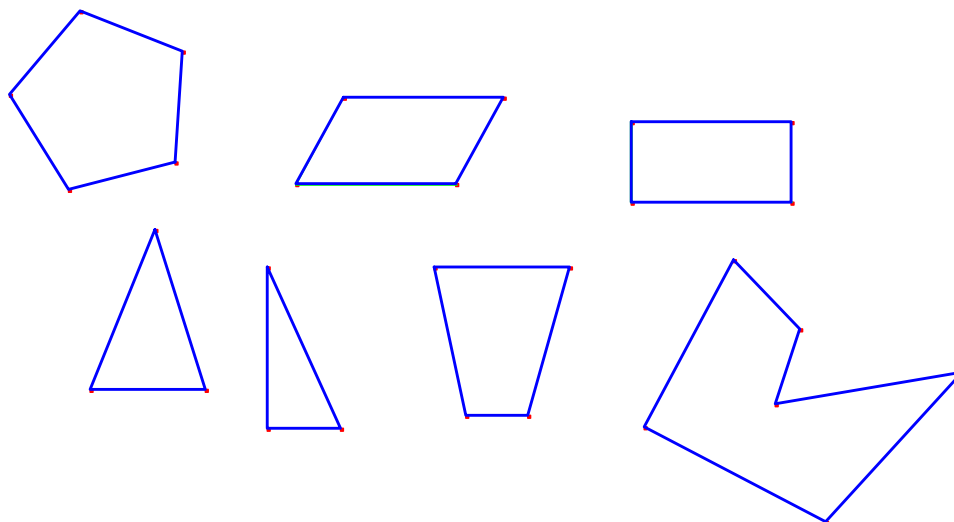

**polynomial** A monomial or sum of monomials.

**Example:** The sum  $4x^2 + (-2x) + (-8)$  can be written as  $4x^2 - 2x - 8$

**premise** A proposition upon which an argument is based or from which a conclusion is drawn.

**prime factorization** Writing an integer as a product of powers of prime numbers.

**Example:**  $30 = 2 \times 3 \times 5$

**probability** The likelihood of an event occurring. The probability of an event must be greater than or equal to 0 and less than or equal to 1.

**product property of proportions** In a proportion  $\frac{a}{b} = \frac{c}{d}$ , the product of the means (b and c) equals the product of the extremes (a and d), or in other words:  $b \cdot c = a \cdot d$ .

**proof** A logical argument that establishes the truth of a statement; a valid argument, expressed in written form, justified by axioms, definitions, and theorems.

**properties of the real numbers** Rules that apply to the operations with real numbers.

**Examples:**

Commutative Property	$a + b = b + a$	$ab = ba$
Associative Property	$a + (b + c) = (a + b) + c$	$a(bc) = (ab)c$
Distributive Property	$a(b + c) = ab + ac$	
Identity	$a + 0 = a$	$a \cdot 1 = a$
Inverse	$a + (-a) = 0$	$a \cdot \frac{1}{a} = 1$
Zero Property		$a \cdot 0 = 0$

**proportional** Two variables are proportional if they maintain a constant ratio.

**Examples:**

If cans of soup cost 75 cents each, the cost of any quantity of cans is proportional to the quantity of cans because the ratio of the total cost to the quantity of cans is always 75 cents:1 can.

The perimeter of any square is proportional to the length of one of its sides because the ratio of the length of one side to the perimeter is always 1:4.

**Pythagorean theorem** The mathematical relationship stating that in any right triangle the sum of the squares of the lengths of the two legs is equal to the square of the length of the hypotenuse; if  $a$  and  $b$  are the lengths of the legs and  $c$  is the length of the hypotenuse, then  $a^2 + b^2 = c^2$ .

## Q

**quadratic equation** An equation that can be written in the form  $ax^2 + bx + c = 0$ , where  $a$ ,  $b$ , and  $c$  are real constants and  $a \neq 0$ .

**quadrilateral** A polygon with 4 sides.

### Examples

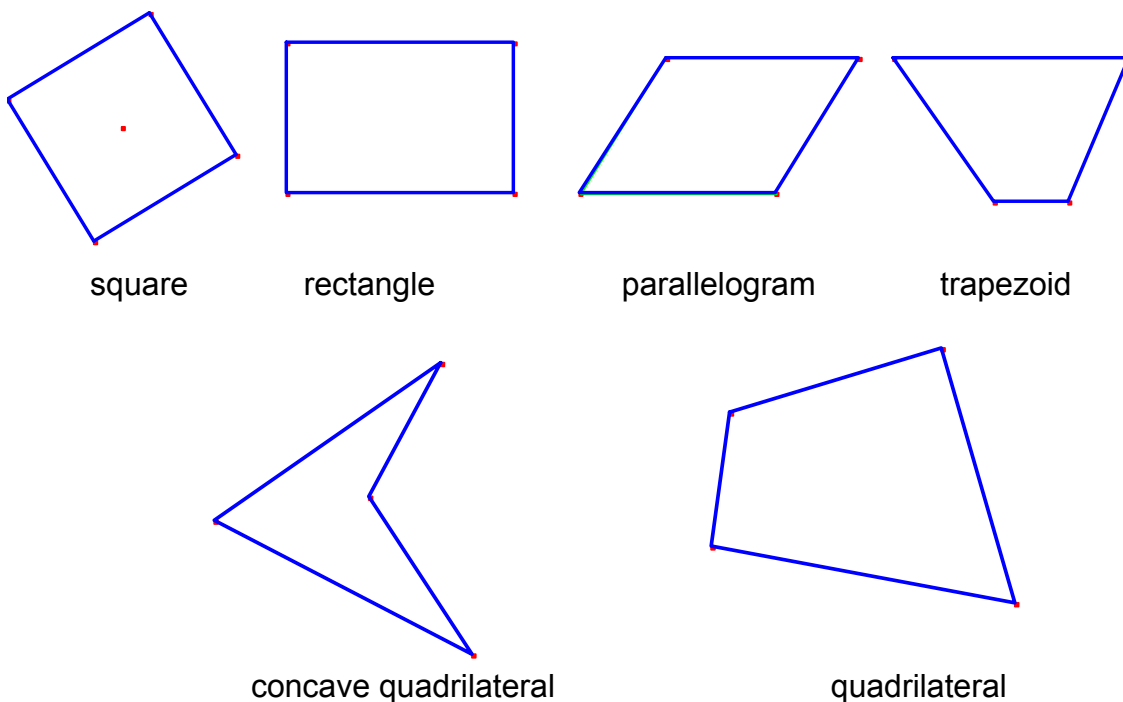

**quantitative** Descriptions using numerical measures such as quantity, height, or age.

## R

**radical** The root of a quantity as indicated by the radical sign.

**radicand** The quantity under a radical sign; a number or expression from which a root is extracted.

**Example:** 3 is the radicand of  $\sqrt{3}$ .

**range (of a data set)** The difference between the maximum and minimum data values in a data set

**Example:** Given the data: 2, 7, -3, 14, -1, 6, 34, 3  
 The minimum value is -3  
 The maximum value is 34  
 The range is  $34 - (-3) = 37$

**rates** A ratio that compares quantities of different units (e.g., miles per hour, price per pound, students per class, heartbeats per minute).

**ratio** A comparison of two quantities having same units (e.g., 2 to 3, 2:3,  $\frac{2}{3}$ ).

**rational coefficient** A coefficient that is a rational number.

**rational expression** The quotient of two polynomials in the form  $\frac{A}{B}$ , where  $A$  and  $B$  are polynomials and  $B \neq 0$ .

**Example:**  $\frac{2x+1}{3x^2-9}$ ,  $3x^2-9 \neq 0$

**rational number** Any number that can be expressed as a ratio in the form  $\frac{a}{b}$  where  $a$  and  $b$  are integers and  $b \neq 0$ . A rational number is either a terminating or repeating decimal.

**real numbers** The set of numbers that includes all rational and irrational numbers.

**Example:**

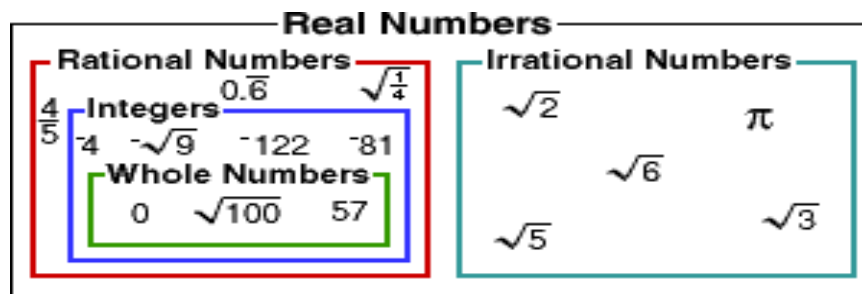

**rectangle** A parallelogram containing one right angle; a quadrilateral with four right angles.

**rectangular coordinates** An ordered pair of real numbers that establishes the location of a point in a coordinate plane using the distances from two perpendicular intersecting lines called the coordinate axes. (See also Cartesian coordinates.)

**rectangular solid** A prism whose six faces are rectangles.

**Example:**

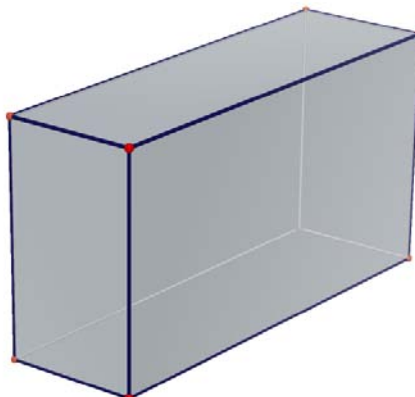

**regular polygon** A polygon which is both equilateral and equiangular.

**Example:**

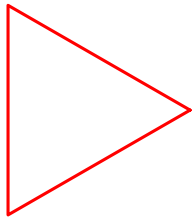

equilateral triangle

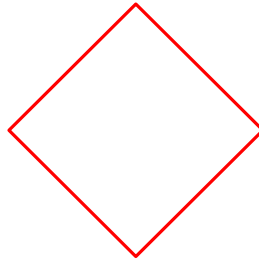

square

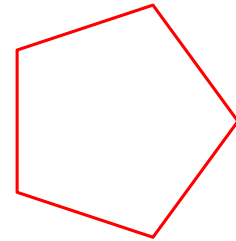

pentagon

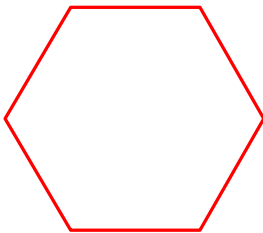

hexagon

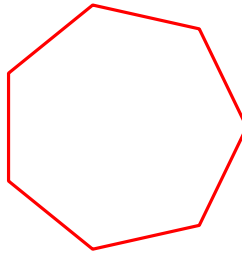

heptagon

...

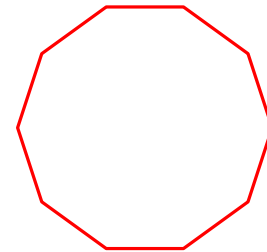

decagon

**relation** A correspondence between two sets; a set of ordered pairs

**Examples:**  $\{(P, Q)\} = \{(4, 5), (2, 20), (7, 5), (-4, 6)\}$

**relative error** The ratio of the absolute error in a measurement to the size of the measurement; often written as a percent and called the percent of error; the absolute error is the difference between an approximation and the exact value.

**representations** Models, (e.g., symbolic, verbal, graphical, numerical, physical, pictorial) used to represent and interpret mathematical problems.

**rhombus** A parallelogram with two adjacent congruent sides; a quadrilateral with four congruent sides.

**right angle** An angle formed by two perpendicular lines, the measure of which is  $90^\circ$ .

**right triangle** A triangle with one right angle.

**root of an equation** A solution to an equation of the form  $f(x) = 0$ .

**Example:** A root of the equation  $y = 6x - 18$  is 3 because when 3 is substituted in for  $x$ , the value of  $y = 0$ .

**Example:** The roots of  $x^2 - x - 2 = 0$  are  $x = 2$  and  $x = -1$ . The equation is true if we substitute either  $x = 2$  or  $x = -1$  into the equation.



**sector of a circle** A region bounded by an arc of the circle and the two radii to the endpoints of the arc.

**Example:** The shaded area in the circle below is a sector of circle O.

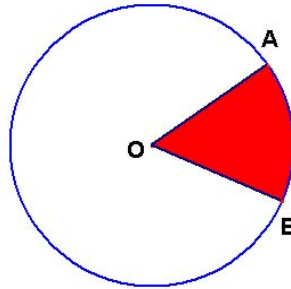

**semi-circle** Either of the arcs of a circle determined by the endpoints of a diameter.

**set** A well-defined collection of items.

**set-builder notation** A notation used to describe the elements of a set.

**Example:** The set of all positive real numbers in set builder notation is  $\{x: x \in \mathbb{R} \text{ and } x > 0\}$   
This is read as "the set of all values of  $x$  such that  $x$  is a real number and  $x$  is greater than 0."

**simplest form** An expression that has been rewritten as simply as possible using the rules of arithmetic and algebra.

**sine** For a given acute angle  $\theta$  in a right triangle,  $\sin \theta$ , is the ratio of the length of the side opposite the acute angle  $\theta$  to the length of the hypotenuse. See also circular function.

**Example:** In this right triangle,  $\sin A = \frac{4}{5}$  and  $\sin B = \frac{3}{5}$

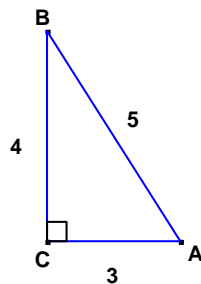

**slope** The measure of the steepness of a line; the ratio of vertical change to horizontal change; if point P is  $(x_1, y_1)$  and point Q is  $(x_2, y_2)$  the slope of  $\overline{PQ}$  is  $\frac{\Delta y}{\Delta x} = \frac{y_2 - y_1}{x_2 - x_1}$ .

**Example:** The slope of the line containing the points A(-3,7) and B(5, -2) is  $\frac{(-2)-(7)}{(5)-(-3)} = \frac{-9}{8}$

**solution set** Any and all value(s) of the variable(s) that satisfy an equation, inequality, system of equations, or system of inequalities.

**square** A rectangle with two congruent adjacent sides.

**square units** The basic unit of area.

**subset** A set consisting of elements from a given set; it may be the empty set.

**Example:** if  $B = \{1,2,3,4,5,6,7\}$  and  $A = \{1,2,5\}$ , then  $A$  is a subset of  $B$ .

**substitution property** Any quantity can be replaced by an equal quantity.

**Example:** If  $a+x=b$  and  $x=c$  then  $a+c=b$ .

**subtraction property of equality** If the same or equal quantities are subtracted from same or equal quantities, then the results are equal.

**Example:** If  $a=b$  then  $a-c=b-c$ .

**surface area** The sum of the areas of all the faces or curved surfaces of a solid figure.

**system of equations/inequalities** A set of two or more equations/inequalities. The solution set contains those values that satisfy all of the equations/inequalities in the system.

## T

**tangent (of an angle)** For a given acute angle  $\theta$  in a right triangle,  $\tan \theta$  is the ratio of the length of the side opposite the acute angle  $\theta$  to the length of the side adjacent to the angle  $\theta$ . See also circular function.

**Example:** In this right triangle,  $\tan A = \frac{4}{3}$  and  $\tan B = \frac{3}{4}$

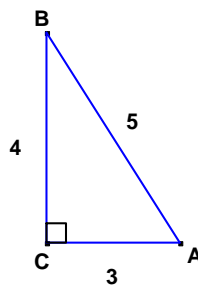



**trapezoid** A quadrilateral with exactly one pair of parallel sides.

**Example:** In the trapezoid below,  $\overline{AB} \parallel \overline{CD}$ .

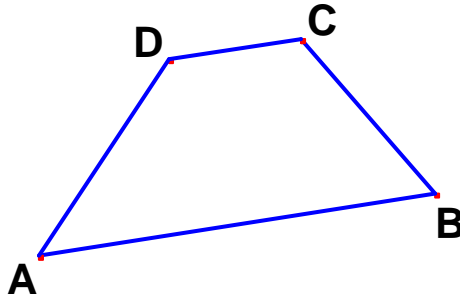

**triangle** A polygon with three sides.

**Examples:**

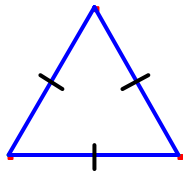

equilateral

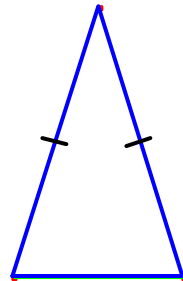

isosceles

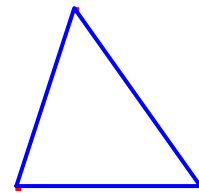

scalene

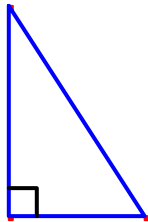

right

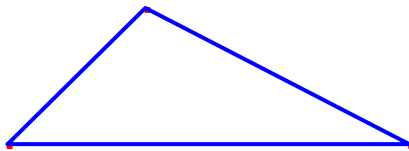

obtuse

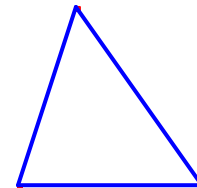

acute

**trigonometry** The branch of mathematics that deals with trigonometric functions.

**trinomial** A polynomial with exactly three terms.

**Examples:**  $a+2b+c$ ,  $x^2-3x+5$ ,  $4c^2d+5cd^2+8$

# U

**undefined** An expression in mathematics which does not have meaning and therefore is not assigned a value.

**Example:** When  $x = 4$ , the expression  $\frac{x+3}{x-4}$  is undefined.

**union of sets** The union of two or more sets is the set of all elements contained in at least one of the sets.

**Example:** if Set  $A = \{2,4,6,8,10\}$  and Set  $B = \{1,2,3,4,5,6\}$ , then the union of sets  $A$  and  $B$ , written as  $A \cup B$ , is  $\{1,2,3,4,5,6,8,10\}$ .

**univariate** A set of data involving one variable.

**universe** The set of all possible specified elements from which subsets are formed. Also known as the universal set.

# V

**valid argument** A logical argument supported by known facts or assumed axioms; an argument in which the premise leads to a conclusion.

**variable** A quantity whose value can change or vary; in algebra, letters often represent variables.

**Venn diagram** A drawing showing relationships among sets.

**Example:** The Venn diagram below shows 14 students. Five students play basketball, seven run track, two play basketball and run track, three play only basketball, five only run track. Four students do not play basketball or run track.

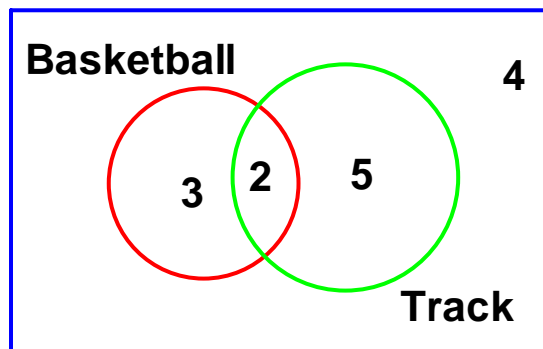

**vertex of an angle** The point of intersection of the two rays that form the sides of the angle.

**vertex of a polygon** A point where the edges of a polygon intersect.

**volume** A measure of the number of cubic units needed to fill the space inside a solid figure.

**visualization** A mental image based on a given description.

## X

**x-axis** One of the two intersecting lines used to establish the coordinates of points in the Cartesian plane; in that plane, the line whose equation is  $y = 0$ ; in space the axis perpendicular to the  $yz$ -plane.

**x-coordinate** The first coordinate in any  $(x,y)$  ordered pair; the number represents how many units the point is located to the left or right of the  $y$ -axis; also called abscissa.

**x-intercept** The point at which the graph of a relation intercepts the  $x$ -axis. The ordered pair for this point has a value of  $y = 0$ .

**Example:** The equation  $y = 8 + 2x$  has an  $x$ -intercept of  $-4$ .

## Y

**y-axis** One of the two intersecting lines used to establish the coordinates of points in the Cartesian plane; in that plane, the line whose equation is  $x = 0$ ; in space the axis perpendicular to the  $xz$ -plane.

**y-coordinate** The second coordinate in any  $(x,y)$  ordered pair; the number represents how many units the point is located above or below of the  $x$ -axis; also called ordinate.

**y-intercept** The point at which a graph of a relation intercepts the  $y$ -axis. The ordered pair for this point has a value of  $x = 0$ .

**Example:** The equation  $y = 8 + 2x$  has a  $y$ -intercept of  $8$ .

## Z

**z-coordinate** The third coordinate in any  $(x,y,z)$  ordered triple; the number represents how many units the point is located above or below of the  $xy$ -plane.

**zero product property** If  $a$  and  $b$  are real numbers, then  $ab = 0$  if and only if  $a = 0$  or  $b = 0$ , or  $a$  and  $b = 0$ .